

# OSPF for ISPs



## ISP Workshops

# OSPF Areas

---

- ❑ It is entirely possible to operate a network in single area with up to 300 routers
- ❑ Areas are used to scale OSPF for larger networks
  - OSPF has a large number of area types
  - **Only “regular” areas are useful for ISPs**
  - Other area types handle redistribution of other routing protocols into OSPF – ISPs don’t redistribute anything into OSPF

# OSPF Areas

- Area is a group of contiguous hosts and networks
  - Reduces routing traffic
- Per area topology database
  - Invisible outside the area
- **Backbone area MUST be contiguous**
  - All other areas must be connected to the backbone

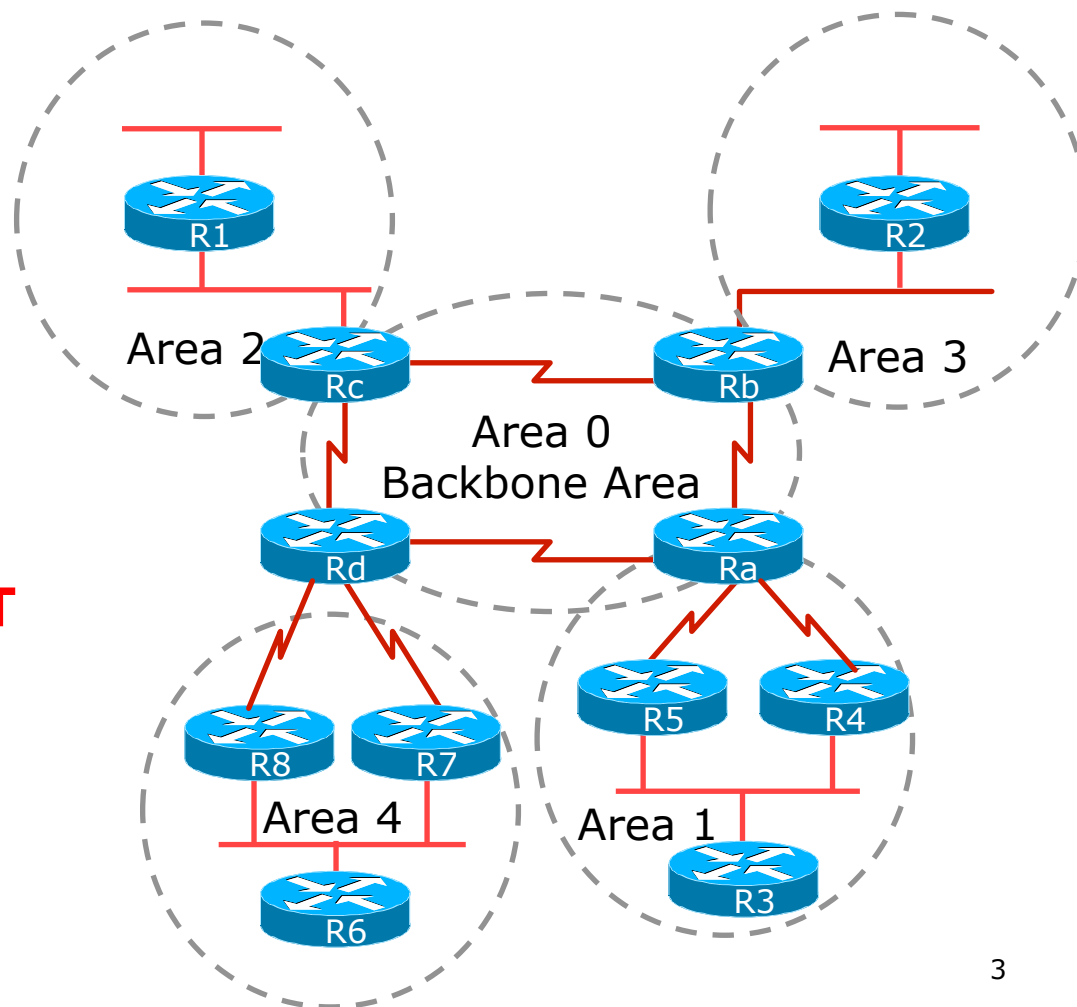

# Virtual Links between OSPF Areas

- ❑ Virtual Link is used when it is not possible to physically connect the area to the backbone
- ❑ **ISPs avoid designs which require virtual links**
  - Increases complexity
  - Decreases reliability and scalability

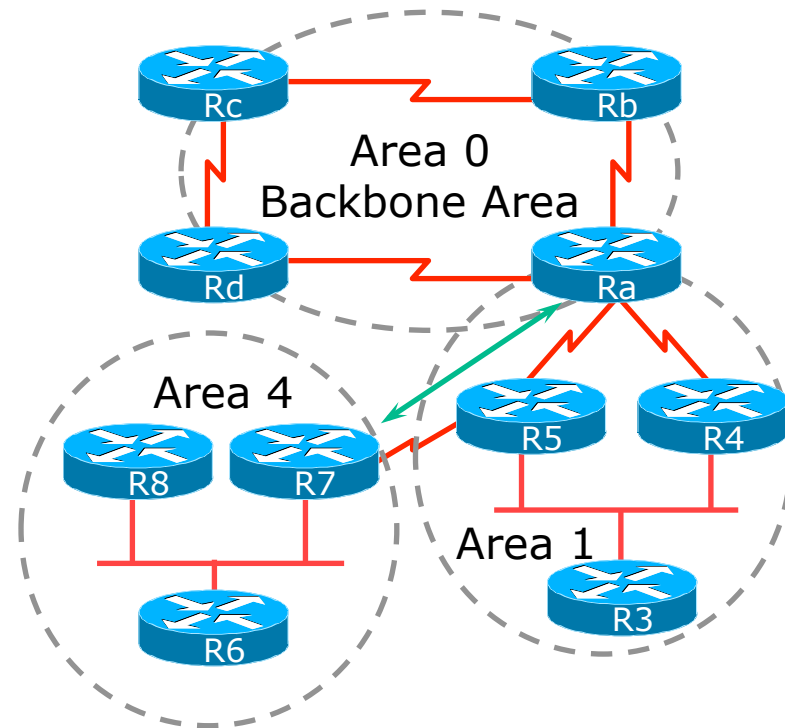

# Classification of Routers

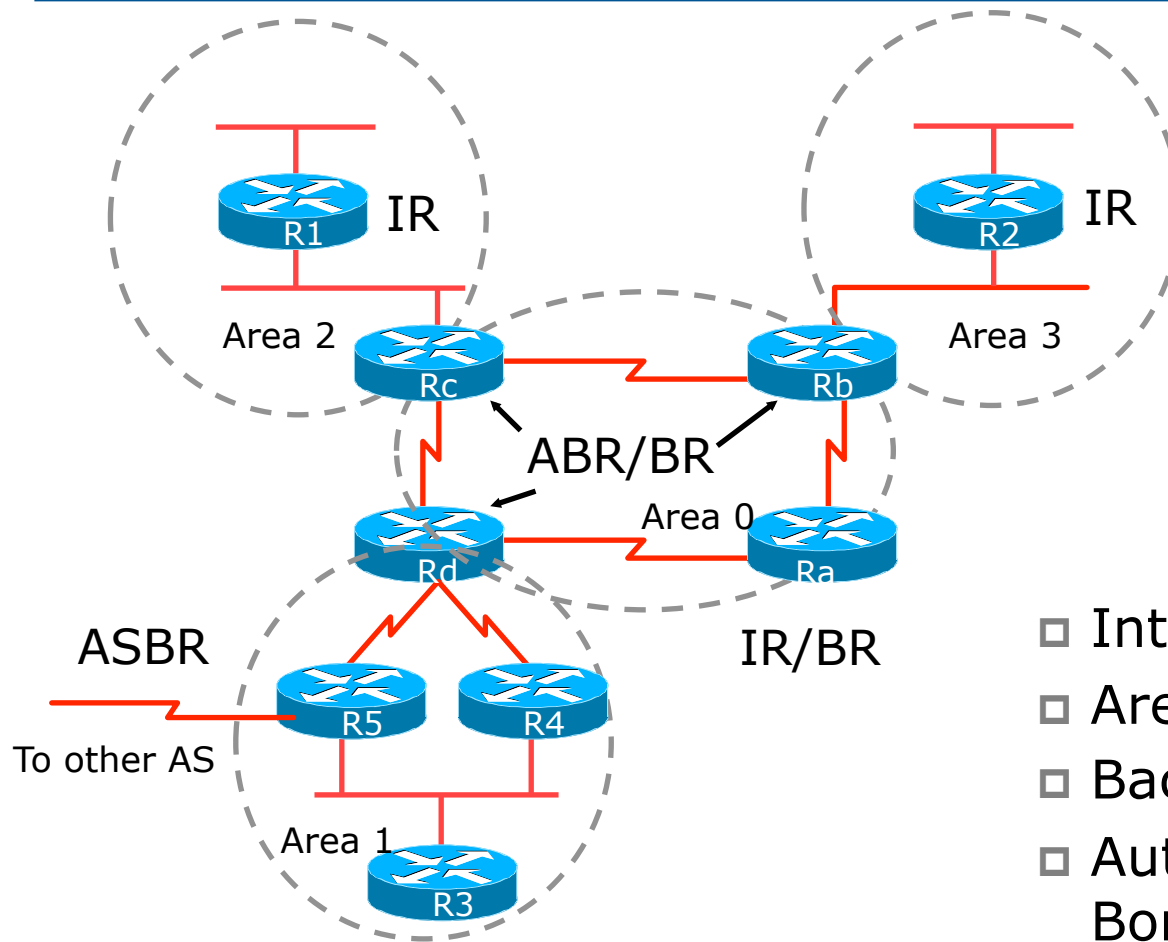

- ❑ Internal Router (IR)
- ❑ Area Border Router (ABR)
- ❑ Backbone Router (BR)
- ❑ Autonomous System Border Router (ASBR)

# OSPF Route Types

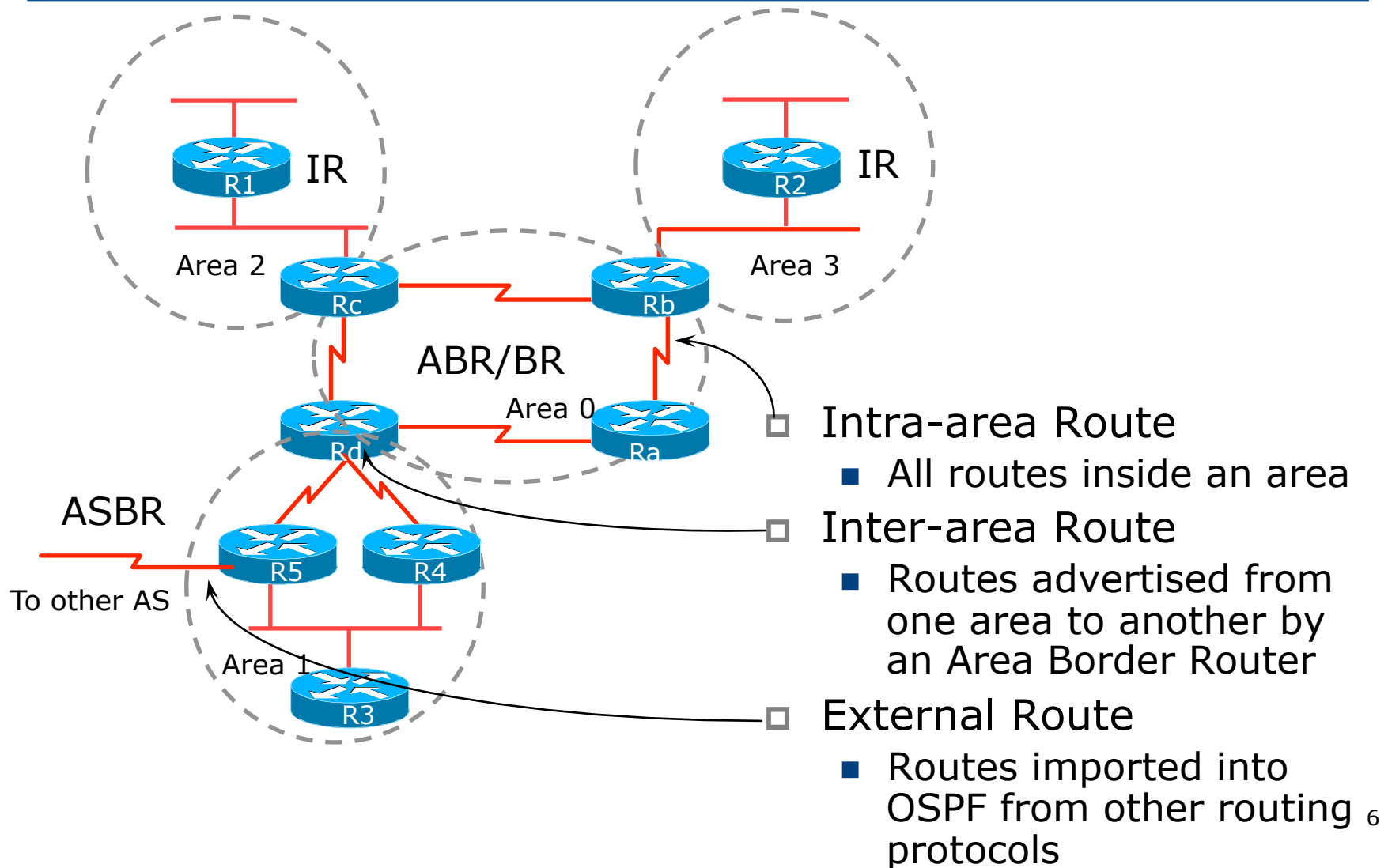

# External Routes

---

- ❑ Prefixes which are redistributed into OSPF from other protocols
- ❑ Flooded unaltered throughout the AS
  - **Recommendation: Avoid redistribution!!**
- ❑ OSPF supports two types of external metrics
  - Type 1 external metrics
  - Type 2 external metrics (Cisco IOS default)

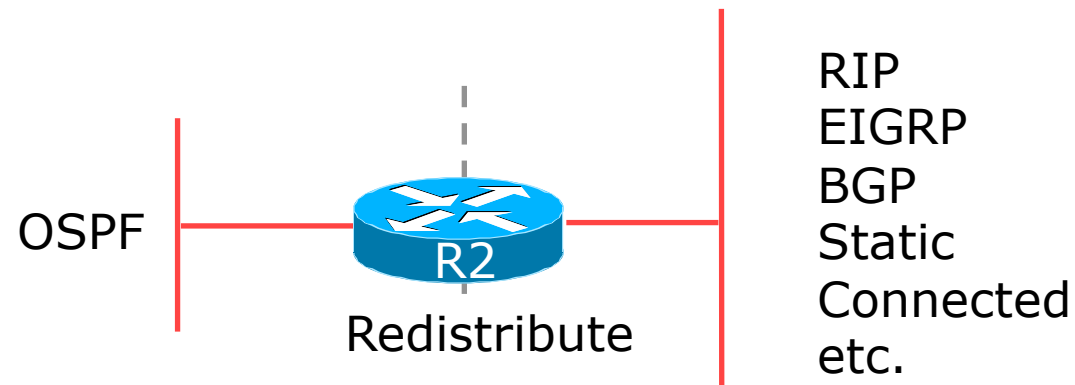

# External Routes

- Type 1 external metric: metrics are added to the summarised internal link cost

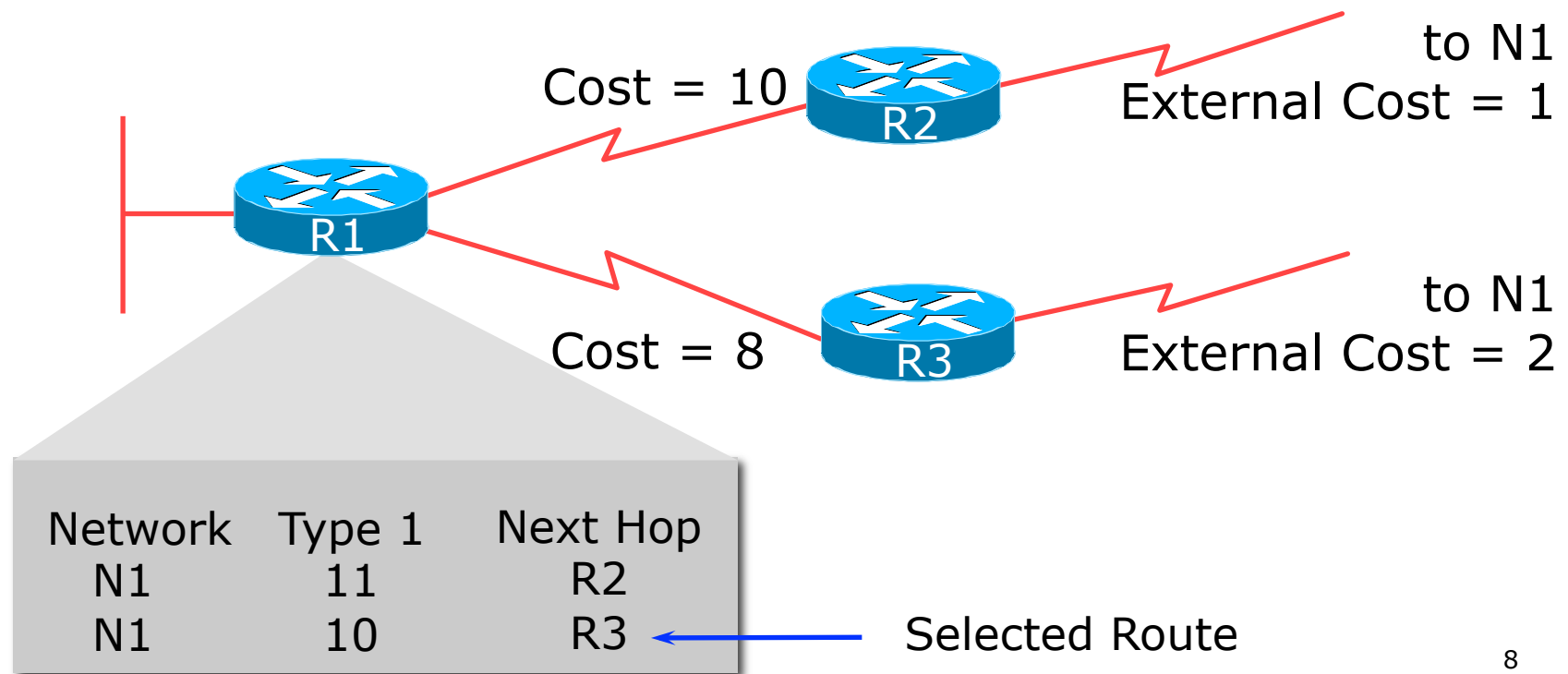



# External Routes

- Type 2 external metric: metrics are compared without adding to the internal link cost

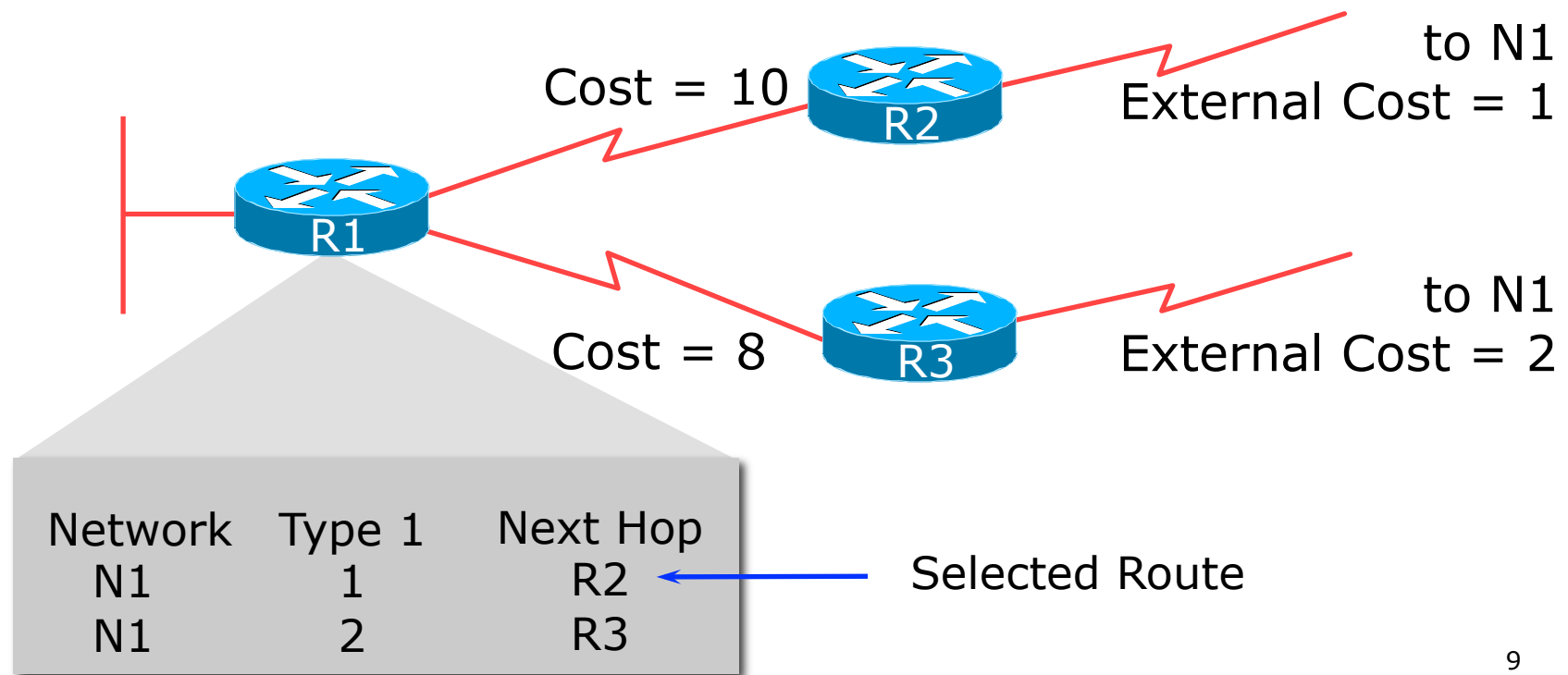

# Topology/Link State Database

---

- ❑ A router has a separate LS database for each area to which it belongs
- ❑ All routers belonging to the same area have identical database
- ❑ SPF calculation is performed separately for each area
- ❑ LSA flooding is bounded by area
- ❑ **Recommendation:**
  - Limit the number of areas a router participates in!!
  - 1 to 3 is fine (typical ISP design)
  - >3 can overload the CPU depending on the area topology complexity

# Inter-Area Route Summarisation

- Prefix or all subnets
- Prefix or all networks
- 'Area range' command

With summarisation

Network	Next Hop
1	R1

Without summarisation

Network	Next Hop
1.A	R1
1.B	R1
1.C	R1

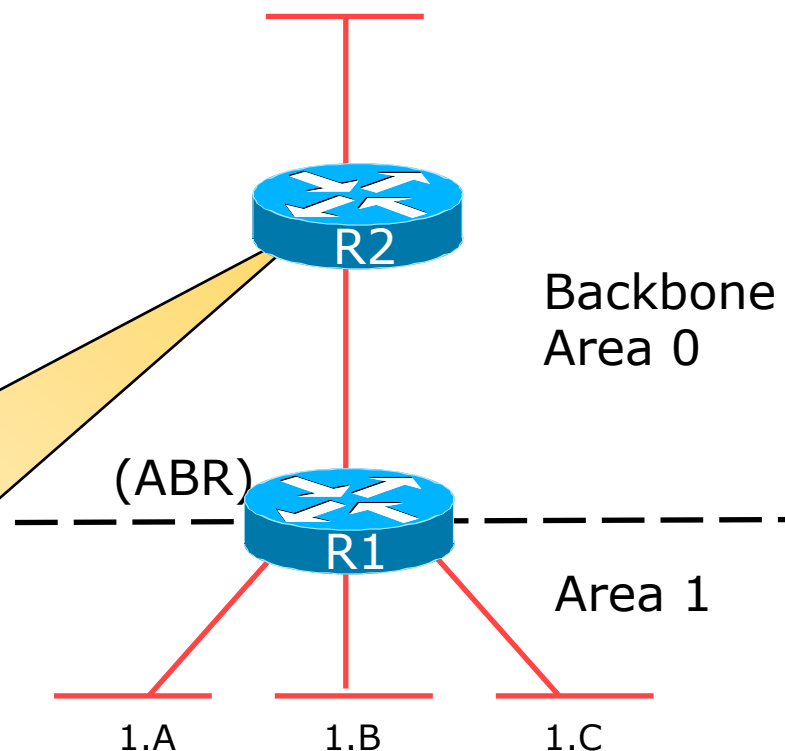

# ISP Use of Areas

---

- ISP networks use:
  - Backbone area
  - Regular area
- Backbone area
  - No partitioning
- Regular area
  - Summarisation of point to point link addresses used within areas
  - Loopback addresses allowed out of regular areas without summarisation (otherwise iBGP won't work)

# Addressing for Areas

---

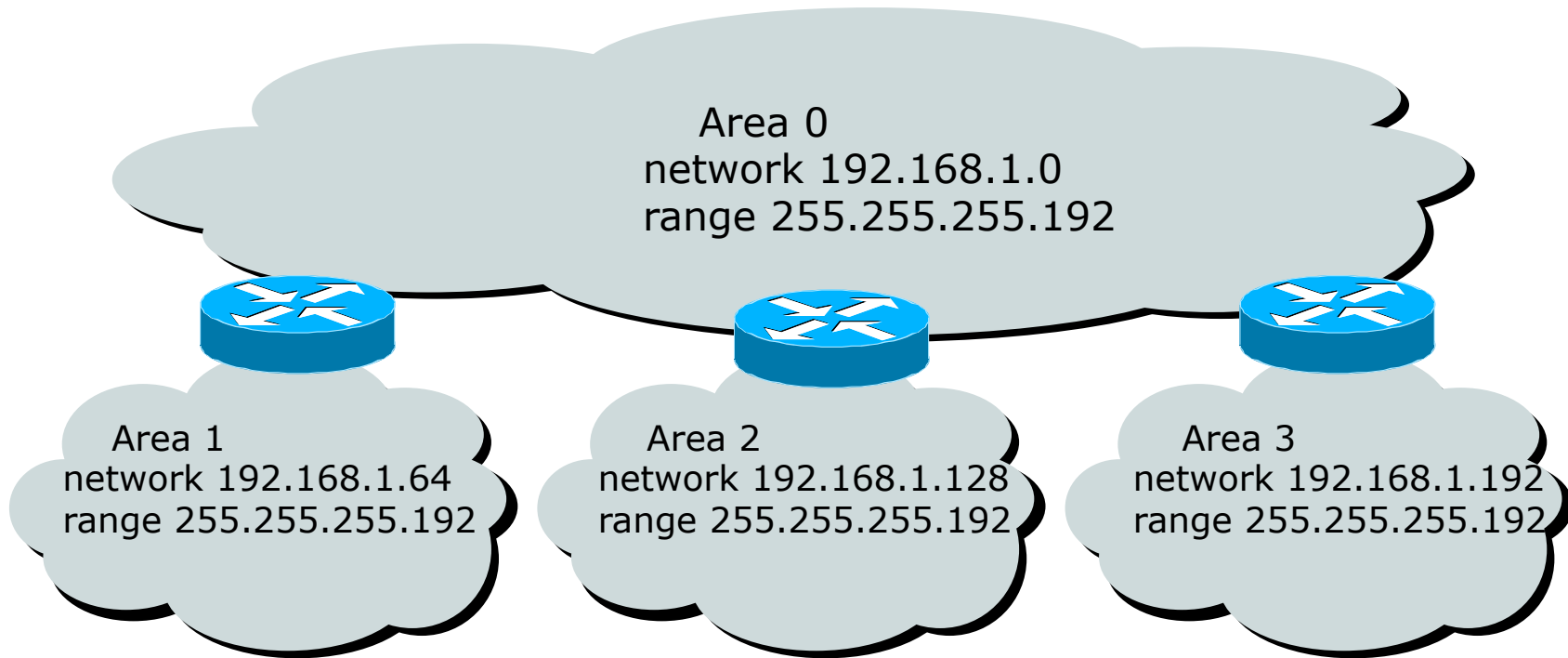

- ❑ Assign contiguous ranges of subnets per area to facilitate summarisation

# OSPF for Service Providers



Configuring OSPF & Adding  
Networks

# OSPF: Configuration

---

- ❑ Starting OSPF in Cisco's IOS
  - `router ospf 42`
    - Where "42" is the process ID
- ❑ OSPF process ID is unique to the router
  - Gives possibility of running multiple instances of OSPF on one router
  - Process ID is not passed between routers in an AS
  - Many ISPs configure the process ID to be the same as their BGP Autonomous System Number

# OSPF: Establishing Adjacencies

---

- ❑ Cisco IOS OSPFv2 automatically tries to establish adjacencies on all defined interfaces (or subnets)
- ❑ Best practice is to disable this
  - Potential security risk: sending OSPF Hellos outside of the autonomous system, and risking forming adjacencies with external networks
  - Example: Only POS4/0 interface will attempt to form an OSPF adjacency

```
router ospf 100
  passive-interface default
  no passive-interface POS4/0
```



# OSPF: Adding Networks

## Option One

---

### ❑ Redistribution:

- Applies to all connected interfaces on the router but sends networks as external type-2s – which are not summarised

```
router ospf 100
```

```
redistribute connected subnets
```

### ❑ **Do NOT do this!** Because:

- Type-2 LSAs flood through entire network
- These LSAs are not all useful for determining paths through backbone; they simply take up valuable space

# OSPF: Adding Networks

## Option Two

---

- Per link configuration – from IOS 12.4 onwards
  - OSPF is configured on each interface (same as ISIS)
  - Useful for multiple subnets per interface

```
interface POS 4/0
  ip address 192.168.1.1 255.255.255.0
  ip address 172.16.1.1 255.255.255.224 secondary
  ip ospf 100 area 0
!
router ospf 100
  passive-interface default
  no passive-interface POS 4/0
```

# OSPF: Adding Networks

## Option Three

---

- ❑ Specific network statements
  - Every active interface with a configured IP address needs an OSPF network statement
  - Interfaces that will have no OSPF neighbours need passive-interface to disable OSPF Hello's
    - ❑ That is: all interfaces connecting to devices outside the ISP backbone (i.e. customers, peers, etc)

```
router ospf 100
  network 192.168.1.0 0.0.0.3 area 51
  network 192.168.1.4 0.0.0.3 area 51
  passive-interface Serial 1/0
```

# OSPF: Adding Networks

## Option Four

---

- Network statements – wildcard mask
  - Every active interface with configured IP address covered by wildcard mask used in OSPF network statement
  - Interfaces covered by wildcard mask but having no OSPF neighbours need passive-interface (or use passive-interface default and then activate the interfaces which will have OSPF neighbours)

```
router ospf 100
  network 192.168.1.0 0.0.0.255 area 51
  passive-interface default
  no passive interface POS 4/0
```

# OSPF: Adding Networks

## Recommendations

---

- ❑ Don't ever use Option 1
- ❑ Use Option 2 if supported; otherwise:
- ❑ Option 3 is fine for core/infrastructure routers
  - Doesn't scale too well when router has a large number of interfaces but only a few with OSPF neighbours
  - → solution is to use Option 3 with “no passive” on interfaces with OSPF neighbours
- ❑ Option 4 is preferred for aggregation routers
  - Or use iBGP next-hop-self
  - Or even ip unnumbered on external point-to-point links

# OSPF: Adding Networks

## Example One (Cisco IOS $\geq$ 12.4)

---

- Aggregation router with large number of leased line customers and just two links to the core network:

```
interface loopback 0
  ip address 192.168.255.1 255.255.255.255
  ip ospf 100 area 0
interface POS 0/0
  ip address 192.168.10.1 255.255.255.252
  ip ospf 100 area 0
interface POS 1/0
  ip address 192.168.10.5 255.255.255.252
  ip ospf 100 area 0
interface serial 2/0:0 ...
  ip unnumbered loopback 0
! Customers connect here ^^^^^^
router ospf 100
  passive-interface default
  no passive interface POS 0/0
  no passive interface POS 1/0
```

# OSPF: Adding Networks

## Example One (Cisco IOS < 12.4)

---

- ▣ Aggregation router with large number of leased line customers and just two links to the core network:

```
interface loopback 0
  ip address 192.168.255.1 255.255.255.255
interface POS 0/0
  ip address 192.168.10.1 255.255.255.252
interface POS 1/0
  ip address 192.168.10.5 255.255.255.252
interface serial 2/0:0 ...
  ip unnumbered loopback 0
! Customers connect here ^^^^^^
router ospf 100
  network 192.168.255.1 0.0.0.0 area 51
  network 192.168.10.0 0.0.0.3 area 51
  network 192.168.10.4 0.0.0.3 area 51
  passive-interface default
  no passive interface POS 0/0
  no passive interface POS 1/0
```

# OSPF: Adding Networks

## Example Two (Cisco IOS $\geq$ 12.4)

---

- Core router with only links to other core routers:

```
interface loopback 0
  ip address 192.168.255.1 255.255.255.255
  ip ospf 100 area 0
interface POS 0/0
  ip address 192.168.10.129 255.255.255.252
  ip ospf 100 area 0
interface POS 1/0
  ip address 192.168.10.133 255.255.255.252
  ip ospf 100 area 0
interface POS 2/0
  ip address 192.168.10.137 255.255.255.252
  ip ospf 100 area 0
interface POS 2/1
  ip address 192.168.10.141 255.255.255.252
  ip ospf 100 area 0
router ospf 100
  passive interface loopback 0
```



# OSPF: Adding Networks

## Example Two (Cisco IOS < 12.4)

---

- Core router with only links to other core routers:

```
interface loopback 0
  ip address 192.168.255.1 255.255.255.255
interface POS 0/0
  ip address 192.168.10.129 255.255.255.252
interface POS 1/0
  ip address 192.168.10.133 255.255.255.252
interface POS 2/0
  ip address 192.168.10.137 255.255.255.252
interface POS 2/1
  ip address 192.168.10.141 255.255.255.252
router ospf 100
  network 192.168.255.1 0.0.0.0 area 0
  network 192.168.10.128 0.0.0.3 area 0
  network 192.168.10.132 0.0.0.3 area 0
  network 192.168.10.136 0.0.0.3 area 0
  network 192.168.10.140 0.0.0.3 area 0
  passive interface loopback 0
```

# OSPF: Adding Networks

## Summary

---

- Key Theme when selecting a technique:  
**Keep the Link State Database Lean**
  - Increases Stability
  - Reduces the amount of information in the Link State Advertisements (LSAs)
  - Speeds Convergence Time

# OSPF for Service Providers



Network Design

# OSPF Design: Addressing

---

- OSPF Design and Addressing go together
  - Objective is to keep the Link State Database lean
  - Create an address hierarchy to match the topology
  - Use separate Address Blocks for loopbacks, network infrastructure, customer interfaces & customers

Customer Address Space

PtP Links

Infrastructure

Loopbacks

# OSPF Design: Addressing

---

- Minimising the number of prefixes in OSPF:
  - **Number loopbacks out of a contiguous address block**
    - But do not summarise these across area boundaries: iBGP peer addresses need to be in the IGP
  - Use contiguous address blocks per area for infrastructure point-to-point links
    - Use `area range` command on ABR to summarise
- With these guidelines:
  - Number of prefixes in area 0 will then be very close to the number of routers in the network
  - It is critically important that the number of prefixes and LSAs in area 0 is kept to the absolute minimum

# OSPF Design: Areas

---

- ❑ Examine physical topology
  - Is it meshed or hub-and-spoke?
- ❑ Use areas and summarisation
  - This reduces overhead and LSA counts
  - (but watch next-hop for iBGP when summarising)
- ❑ Don't bother with the various stub areas
  - No benefits for ISPs, causes problems for iBGP
- ❑ Push the creation of a backbone
  - Reduces mesh and promotes hierarchy

# OSPF Design: Areas

---

- ❑ One SPF per area, flooding done per area
  - Watch out for overloading ABRs
- ❑ Avoid externals in OSPF
  - **DO NOT REDISTRIBUTE** into OSPF
  - External LSAs flood through entire network
- ❑ Different types of areas do different flooding
  - Normal areas
  - Stub areas
  - Totally stubby (stub no-summary)
  - Not so stubby areas (NSSA)

# OSPF Design: Areas

---

- ❑ Area 0 **must** be contiguous
  - Do NOT use virtual links to join two Area 0 islands
- ❑ Traffic between two non-zero areas always goes via Area 0
  - **There is no benefit in joining two non-zero areas together**
  - Avoid designs which have two non-zero areas touching each other
  - (Typical design is an area per PoP, with core routers being ABR to the backbone area 0)



# OSPF Design: Summary

---

- Think Redundancy
  - Dual Links out of each area – using metrics (cost) for traffic engineering
- Too much redundancy...
  - Dual links to backbone in stub areas must be the same cost – other wise sub-optimal routing will result
  - Too Much Redundancy in the backbone area without good summarisation will effect convergence in the Area 0

# OSPF Areas: Migration

---

- Where to place OSPF Areas?
  - **Follow the physical topology!**
  - Remember the earlier design advice
- Configure area at a time!
  - Start at the outermost edge of the network
  - Log into routers at either end of a link and change the link from Area 0 to the chosen Area
  - Wait for OSPF to re-establish adjacencies
  - And then move onto the next link, etc
  - Important to ensure that there is never an Area 0 island anywhere in the migrating network

# OSPF Areas: Migration

---

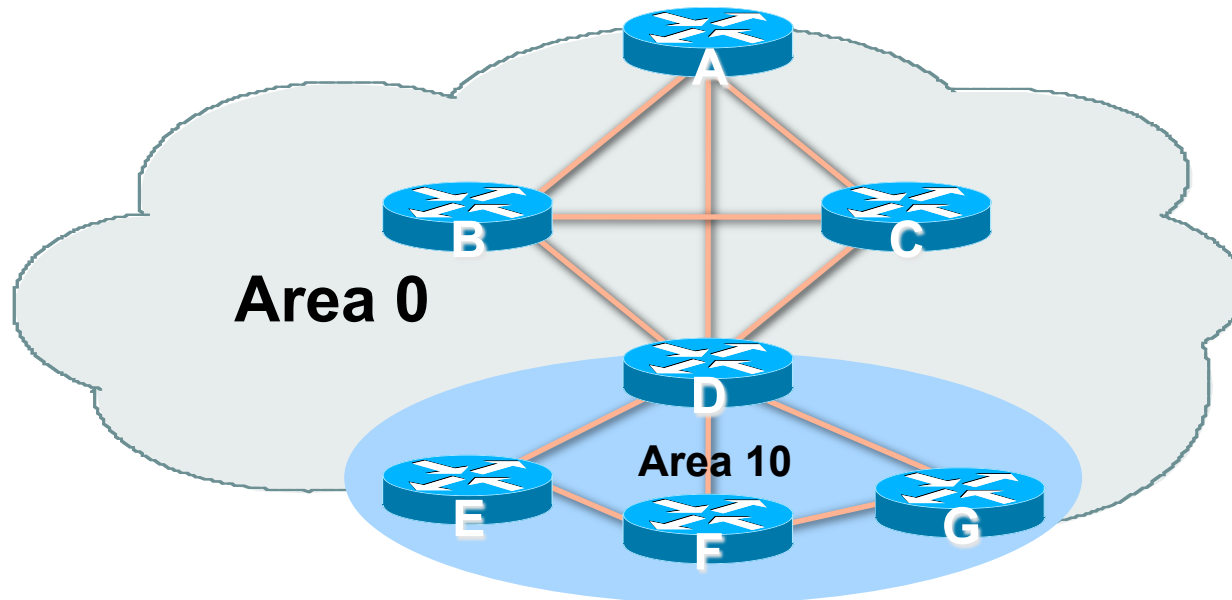

- ❑ Migrate small parts of the network, one area at a time
  - Remember to introduce summarisation where feasible
- ❑ With careful planning, the migration can be done with minimal network downtime

# OSPF for Service Providers



Useful features for ISPs

# Areas

---

- An area is stored as a 32-bit field:
  - Defined in IPv4 address format (i.e. Area 0.0.0.0)
  - Can also be defined using single decimal value (i.e. Area 0)
- 0.0.0.0 reserved for the backbone area

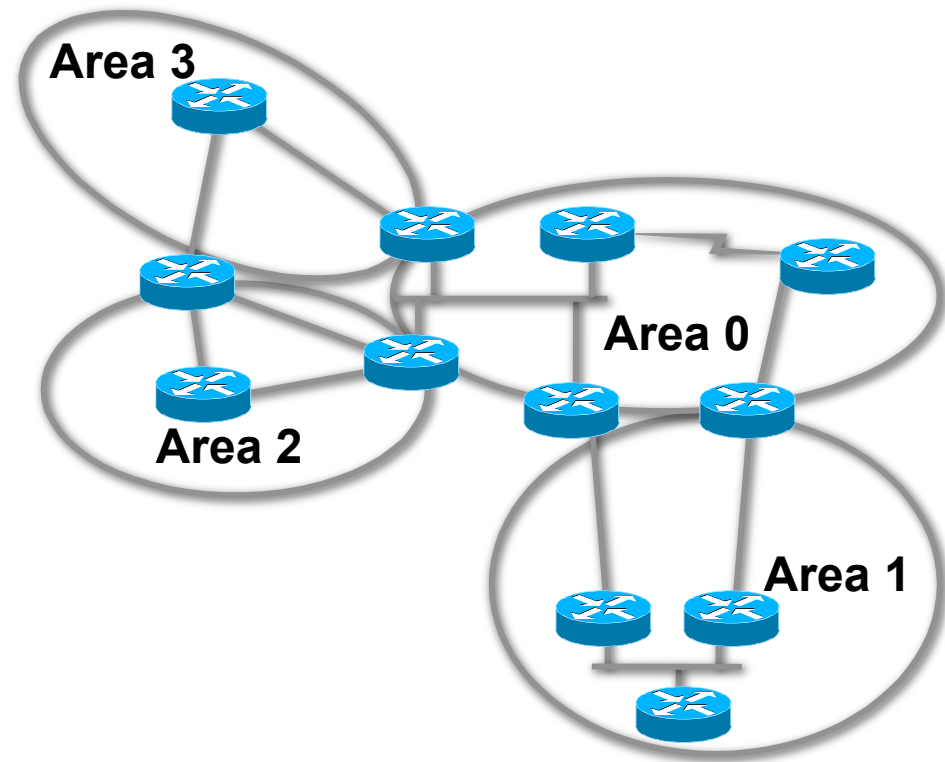

# Logging Adjacency Changes

---

- ❑ The router will generate a log message whenever an OSPF neighbour changes state
- ❑ Syntax:
  - **[no] [ospf] log-adjacency-changes**
  - (OSPF keyword is optional, depending on IOS version)
- ❑ Example of a typical log message:
  - `%OSPF-5-ADJCHG: Process 1, Nbr 223.127.255.223 on Ethernet0 from LOADING to FULL, Loading Done`

# Number of State Changes

---

- The number of state transitions is available via SNMP (`ospfNbrEvents`) and the CLI:
  - `show ip ospf neighbor [type number] [neighbor-id] [detail]`
  - Detail—(Optional) Displays all neighbours given in detail (list all neighbours). When specified, neighbour state transition counters are displayed per interface or neighbour ID

## State Changes (Continued)

---

- To reset OSPF-related statistics, use the `clear ip ospf counters` command
  - This will reset neighbour state transition counters per interface or neighbour id
  - `clear ip ospf counters [neighbor [<type number>] [neighbor-id]]`



# Router ID

---

- ❑ If the loopback interface exists and has an IP address, that is used as the router ID in routing protocols – **stability!**
- ❑ If the loopback interface does not exist, or has no IP address, the router ID is the highest IP address configured – **danger!**
- ❑ OSPF sub command to manually set the Router ID:
  - `router-id <ip address>`

# Cost & Reference Bandwidth

---

- ❑ Bandwidth used in Metric calculation
  - $\text{Cost} = 10^8 / \text{bandwidth}$
  - Not useful for interface bandwidths > 100 Mbps
- ❑ Syntax:
  - `ospf auto-cost reference-bandwidth <reference-bw>`
- ❑ Default reference bandwidth still 100 Mbps for backward compatibility
- ❑ Most ISPs simply choose to develop their own cost strategy and apply to each interface type

# Cost: Example Strategy

---

100GE	100Gbps	cost = 1
40GE/OC768	40Gbps	cost = 2
10GE/OC192	10Gbps	cost = 5
OC48	2.5Gbps	cost = 10
GigEthernet	1Gbps	cost = 20
OC12	622Mbps	cost = 50
OC3	155Mbps	cost = 100
FastEthernet	100Mbps	cost = 200
Ethernet	10Mbps	cost = 500
E1	2Mbps	cost = 1000

# Default routes

---

- Originating a default route into OSPF
  - `default-information originate metric <n>`
  - Will originate a default route into OSPF if there is a matching default route in the Routing Table (RIB)
  - The optional **always** keyword will always originate a default route, even if there is no existing entry in the RIB

# Clear/Restart

---

- ❑ **OSPF clear commands**
  - If no process ID is given, all OSPF processes on the router are assumed
- ❑ **clear ip ospf [pid] redistribution**
  - This command clears redistribution based on OSPF routing process ID
- ❑ **clear ip ospf [pid] counters**
  - This command clears counters based on OSPF routing process ID
- ❑ **clear ip ospf [pid] process**
  - This command will restart the specified OSPF process. It attempts to keep the old router-id, except in cases where a new router-id was configured or an old user configured router-id was removed. Since this command can potentially cause a network churn, a user confirmation is required before performing any action

# Use OSPF Authentication

---

- ❑ Use authentication
  - Too many operators overlook this basic requirement
- ❑ When using authentication, use the MD5 feature
  - Under the global OSPF configuration, specify:

```
area <area-id> authentication message-digest
```
  - Under the interface configuration, specify:

```
ip ospf message-digest-key 1 md5 <key>
```
- ❑ Authentication can be selectively disabled per interface with:

```
ip ospf authentication null
```

# Point to Point Ethernet Links

---

- ❑ For any broadcast media (like Ethernet), OSPF will attempt to elect a designated and backup designated router when it forms an adjacency
  - If the interface is running as a point-to-point WAN link, with only 2 routers on the wire, configuring OSPF to operate in "point-to-point mode" scales the protocol by reducing the link failure detection times
  - Point-to-point mode improves convergence times on Ethernet networks because it:
    - ❑ Prevents the election of a DR/BDR on the link,
    - ❑ Simplifies the SPF computations and reduces the router's memory footprint due to a smaller topology database.

```
interface fastethernet0/2
  ip ospf network point-to-point
```

# Tuning OSPF (1)

---

## □ DR/BDR Selection

- `ip ospf priority 100` (default 1)
- This feature should be in use in your OSPF network
- Forcibly set your DR and BDR per segment so that they are known
- Choose your most powerful, or most idle routers, so that OSPF converges as fast as possible under maximum network load conditions
- Try to keep the DR/BDR limited to one segment each



# Tuning OSPF (2)

---

- OSPF startup
  - `max-metric router-lsa on-startup wait-for-bgp`
  - Avoids blackholing traffic on router restart
  - Causes OSPF to announce its prefixes with highest possible metric until iBGP is up and running
  - When iBGP is running, OSPF metrics return to normal, make the path valid
  
- ISIS equivalent:
  - `set-overload-bit on-startup wait-for-bgp`

# Tuning OSPF (3)

---

## □ Hello/Dead Timers

- `ip ospf hello-interval 3` (default 10)
- `ip ospf dead-interval 15` (default is 4x hello)
- This allows for faster network awareness of a failure, and can result in faster reconvergence, but requires more router CPU and generates more overhead

## □ LSA Pacing

- `timers lsa-group-pacing 300` (default 240)
- Allows grouping and pacing of LSA updates at configured interval
- Reduces overall network and router impact

# Tuning OSPF (4)

---

## □ OSPF Internal Timers

- `timers spf 2 8` (default is 5 and 10)
- Allows you to adjust SPF characteristics
- The first number sets wait time from topology change to SPF run
- The second is hold-down between SPF runs
- BE CAREFUL WITH THIS COMMAND; if you're not sure when to use it, it means you don't need it; default is sufficient 95% of the time

# Tuning OSPF (5)

---

- ❑ LSA filtering/interface blocking
  - Per interface:
    - ❑ `ip ospf database-filter all out` (no options)
  - Per neighbor:
    - ❑ `neighbor 1.1.1.1 database-filter all out` (no options)
  - OSPFs router will flood an LSA out all interfaces except the receiving one; LSA filtering can be useful in cases where such flooding unnecessary (i.e., NBMA networks), where the DR/BDR can handle flooding chores
  - `area <area-id> filter-list <acl>`
  - Filters out specific Type 3 LSAs at ABRs
- ❑ Improper use can result in routing loops and black-holes that can be very difficult to troubleshoot

# Summary

---

- ❑ OSPF has a bewildering number of features and options
- ❑ Observe ISP best practices
- ❑ Keep design and configuration simple
- ❑ Investigate tuning options and suitability for your own network
  - Don't just turn them on!

# OSPF for ISPs



ISP Workshops